

MODEL 9078 UNIVERSAL AIR KNIFE PLUMBING KIT INSTALLATION & MAINTENANCE

This Model 9078 Universal Air Knife Plumbing Kit is used to interconnect the compressed air inlets on the bottom of any two Air Knives with a combined length up to and including 84" (2134mm). The Model 9079 Universal Air Knife Plumbing Kit should be used for lengths over 84" (2134mm). The components of this kit have been sized appropriately to obtain best performance from the Air Knives (maintain uniform airflow across the entire length).

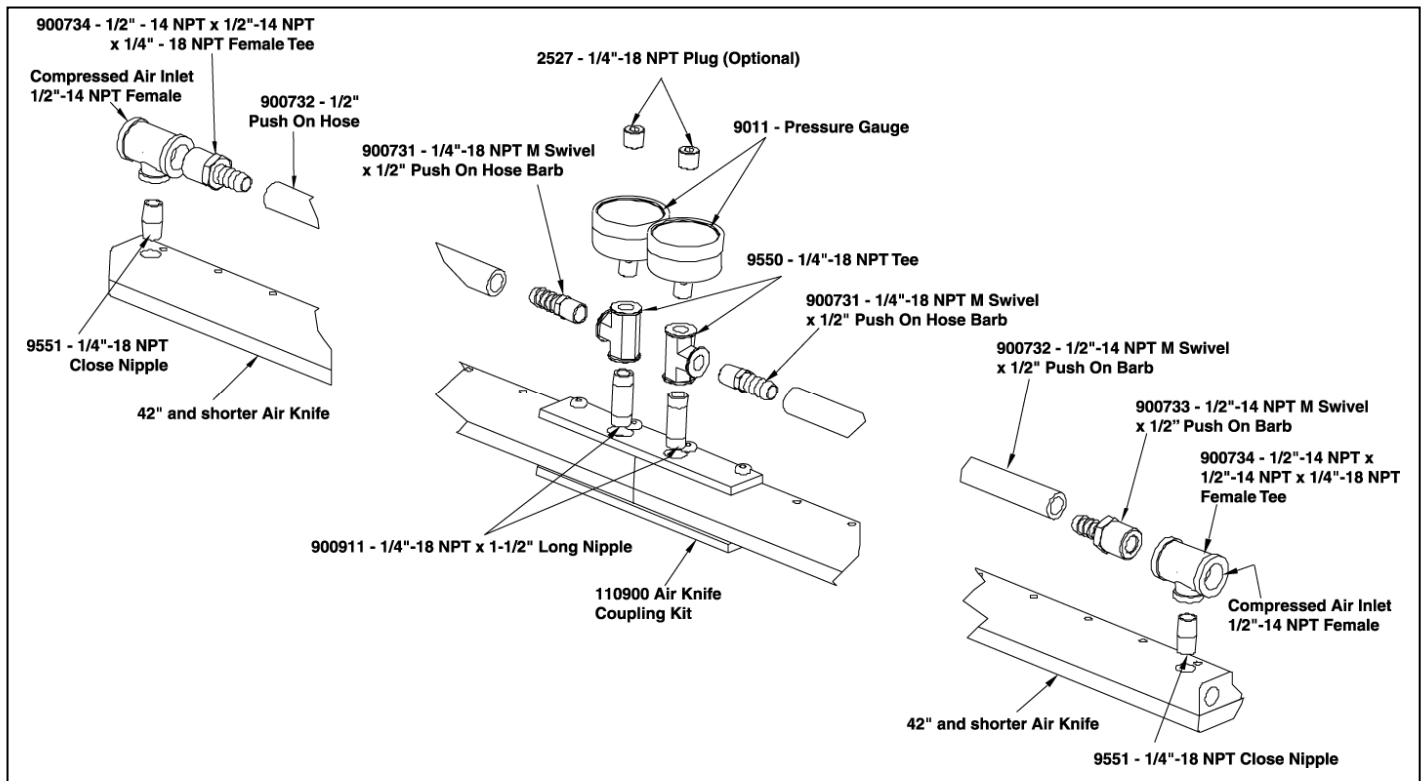

Pipe thread sealant should be applied to all threads (small packet included). Avoid the inside diameter of the fitting so it does not enter into the Air Knife.

- STEP 1** – In the two center inlets, through the coupling bracket, install two Model 900911 ¼ NPT Long Nipples into the compressed air inlets on the bottom of the Air Knives.
- STEP 2** – Install the Model 9550 ¼ x ¼ x ¼ NPT female Pipe Tees onto those Model 900911 Long Nipples and tighten. Be sure the side ¼ NPT female connections are directed toward the ends of the Air Knife.
- STEP 3** – In the remaining bottom ports, install the Model 9551 ¼ NPT Close Nipples into the compressed air inlets. Install Model 900734 ½ x ½ x ¼ NPT female Pipe Tees onto the Close Nipples and tighten. Make sure the outlets are oriented (as shown above) along the length of the knife.
- STEP 4** – Hand tighten (2) Model 900733 ½ NPT x ½ Hose Barbs into the Model 900734 ½ x ½ x ¼ NPT female Pipe Tees opposite the side where the plant compressed air will be supplied. On the Model 9550 Tees at the center of the Air Knife, hand tighten (2) Model 900731 ¼ NPT x ½ Hose Barbs into the inlet that points toward the end of the knife.
- STEP 5** – Determine the length of hose that is necessary by measuring from outside the yellow collar of the one Barb fitting to outside the yellow collar on the opposite fitting. For a tight hose, cut the hose to this exact length. (Increasing the hose length will result in a loose hose).

STEP 6 – Remove hand tightened Barb fittings and push the hose onto the Hose Barbs. You may use a glycerin based lubricant such as soap (not included). **DO NOT USE AN OIL BASED LUBRICANT TO INSTALL THE FITTINGS.**

STEP 7 – Install and tighten the ¼ NPT male ends of the hose into the Model 9550 ¼ NPT female Tee connections. Install and tighten the ½ NPT male ends of the hose into the Model 900734 ½ NPT female Tee connections.

STEP 8 – (2) Model 9011 Pressure Gauges have been provided to monitor the pressure at the Air Knife. You may choose to install them or the (2) Model 2527 Pipe Plugs into the remaining ¼ NPT female connection of each Model 9550 Tee. Your Air Knife is now ready for installation. **Please note that you will need to supply compressed air to each ½ NPT inlet at the ends of the air knife.**

If you have any questions or problems, please contact an EXAIR Application Engineer at:

Toll Free: 1-800-903-9247 (U.S. & Canada)
Telephone: 513 671-3322 outside of U.S. & Canada
Toll Free Fax: 866-329-3924 (U.S. & Canada)
FAX: 513 671-3363 outside of U.S. & Canada
E-mail: techhelp@exair.com
Website: www.exair.com