

## MODEL 9076 UNIVERSAL AIR KNIFE PLUMBING KIT INSTALLATION & MAINTENANCE

This Model 9076 Universal Air Knife Plumbing Kit is used to interconnect the compressed air inlets on each end of any single Air Knife that has a length up to 42" (1067mm). The Model 9077 Universal Air Knife Plumbing Kit should be used for lengths over 42" (1067mm). The components of this kit have been sized appropriately to obtain best performance from the Air Knife (maintain uniform airflow across the entire length). Air Knives less than 24" (610mm) can be supplied at one compressed air inlet.

**To connect bottom compressed air inlets, use this diagram.**

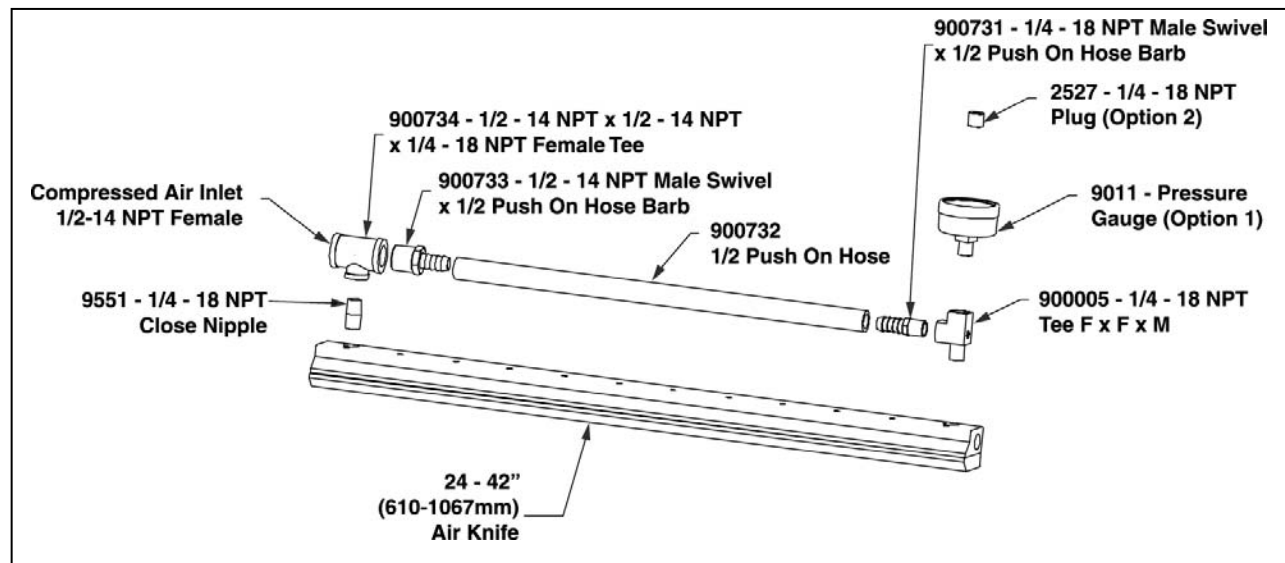

Pipe thread sealant should be applied to all threads (small packet included). Avoid the inside diameter of the fitting so it does not enter into the Air Knife.

- STEP 1** – Install the Model 9551 ¼ NPT Close Nipple into the compressed air inlet on the bottom of the Air Knife. This goes on the end that will be connected to the plant compressed air supply.
- STEP 2** – Install the Model 900734 ½ x ½ x ¼ NPT female pipe Tee on to that Model 9551 Close Nipple and tighten. Be sure the ½ NPT female connections are directed toward the ends of the Air Knife.
- STEP 3** – Install the Model 900005 ¼ NPT male/female pipe Tee into the compressed air inlet on the opposite end of the Air Knife (installing the male NPT connection of the pipe Tee into the Air Knife). Tighten and direct the ¼ NPT female connection toward the opposite end of the Air Knife.
- STEP 4** – Hand tighten the Model 900733 ½ NPT x ½ hose barb into the Model 900734 ½ x ½ x ¼ NPT female Pipe Tee opposite the side where the plant compressed air will be supplied. On the Model 900005 Tee at the opposite end of the Air Knife, hand tighten the Model 900731 ¼ NPT x ½ hose barb into the inlet that points directly at the other barb fitting.
- STEP 5** – Determine the length of hose that is necessary by measuring from outside the yellow collar of the one barb fitting to the outside the yellow collar on the opposite fitting. For a tight hose, cut the hose to this exact length. (Increasing the hose length will result in a loose hose).
- STEP 6** – Remove hand tightened barb fittings and push the hose on to the hose barbs. You may use a glycerin based lubricant such as soap (not included). **DO NOT USE AN OIL BASED LUBRICANT TO INSTALL THE FITTINGS.**

**STEP 7** – Install and tighten the ¼ NPT male end of the hose into the Model 900005 ¼ NPT female Tee connection. Install and tighten the ½ NPT male end of the hose into the Model 900734 ½ NPT female Tee connection.

**STEP 8** – A Model 9011 Pressure Gauge is provided to monitor the pressure at the Air Knife. You may choose to install it or the Model 2527 Pipe Plug into the remaining ¼ NPT female connection of the Model 900005 Tee. Your Air Knife is now ready for installation.

To connect compressed air inlets on each end, use this diagram.

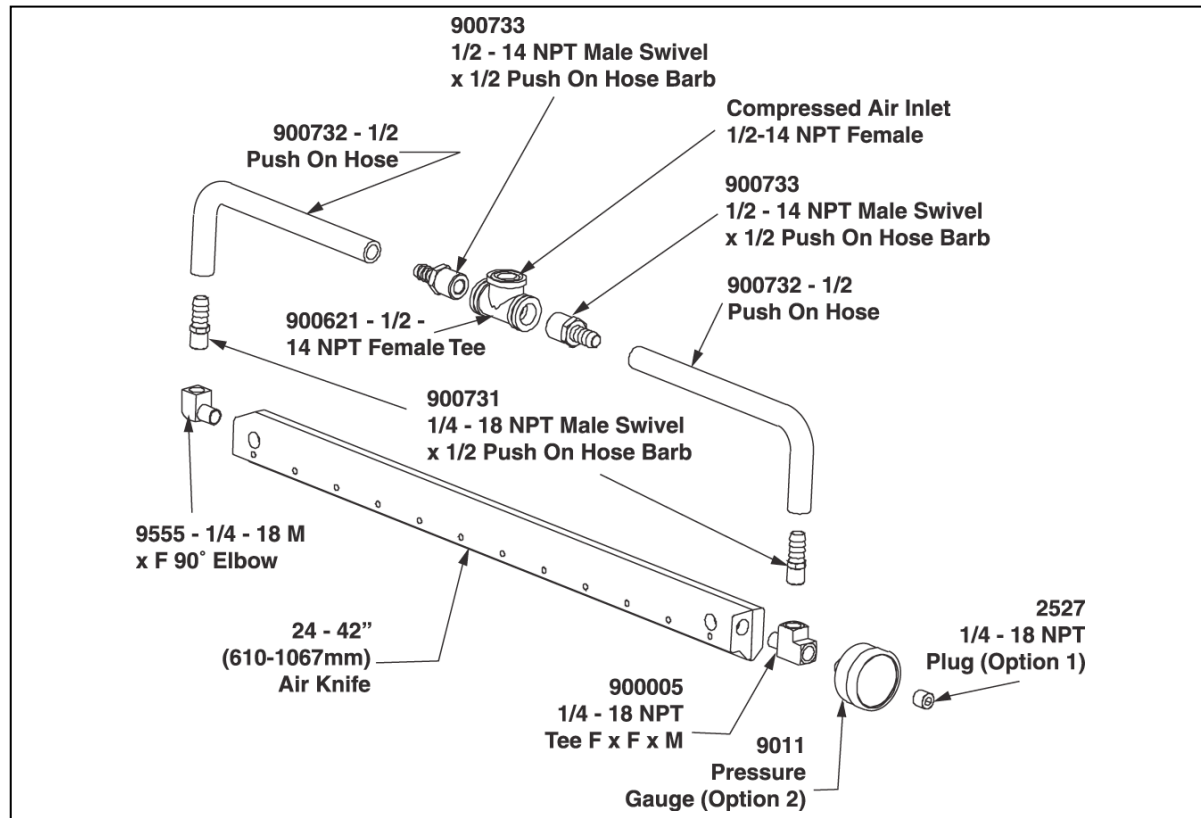

Pipe thread sealant should be applied to all threads (small packet included). Avoid the inside diameter of the fitting so it does not enter into the Air Knife.

**STEP 1** – Install the male ¼ NPT thread of the Model 900005 Tee into the compressed air inlet on one end of the Air Knife.

**STEP 2** – Install the Model 9555 ¼ NPT male x ¼ NPT female 90 degree Elbow into the compressed air inlet on the opposite end of the Air Knife.

**STEP 3** – Hand tighten the (2) Model 900731 ¼ NPT x ½ Hose Barbs into the Model 900005 ¼ NPT male/female pipe Tee on the one end and into the Model 9555 ¼ NPT male x ¼ NPT female 90 degree Elbow on the other.

**STEP 4** – Using the (2) Model 900733 ½ NPT x ½ Hose Barbs, hand tighten one into each side of the Model 900621 ½ NPT female pipe Tee. Place the hand tightened assembly at the center of the Air Knife.

**STEP 5** – Determine the length of hose necessary by measuring from outside the yellow collar on the Model 900733 ½ NPT x ½ Hose Barb to the hex portion of the Model 900731 ¼ NPT x ½ Hose Barb. Add two inches to your measurement to avoid any potential kinks in the hose. Cut the hose to this length.

**STEP 6** - Remove hand tightened barb fittings and push the hose on to the hose bars. You may use a glycerin based lubricant such as soap (not included). **DO NOT USE AN OIL BASED LUBRICANT TO INSTALL THE FITTINGS.**

**STEP 7** – Install and tighten the Model 900731 ¼ NPT male fittings into the ¼ NPT female Elbows. Install and tighten the Model 900733 ½ NPT male connections into opposite ends of the Model 900621 ½ NPT pipe Tee.

**STEP 8** - A Model 9011 Pressure Gauge is provided to monitor the pressure at the Air Knife. You may choose to install it or the Model 2527 Pipe Plug into the remaining ¼ NPT female connection of the Model 900005 Tee. Your Air Knife is now ready for installation.

If you have any questions or problems, please contact an EXAIR Application Engineer at:

Toll Free: 1-800-903-9247 (U.S. & Canada)  
Telephone: 513 671-3322 outside of U.S. & Canada  
Toll Free Fax: 866-329-3924 (U.S. & Canada)  
FAX: 513 671-3363 outside of U.S. & Canada  
E-mail: [techhelp@exair.com](mailto:techhelp@exair.com)  
Website: [www.exair.com](http://www.exair.com)