

RECEIVER TANK INSTALLATION & MAINTENANCE

Most areas require a permit to install and operate a receiver tank when located in a public place or place of employment. Please consult your local code requirements prior to installation.

Pressure tank has a primer finish

Temperature rating is -20° to 450°F

Tank maximum pressure is 200 PSIG

No plugs are included for open ports. **User must supply pressure rated plugs and pressure relief valve.**

Weight is 165 lbs. (75 kg)

EXAIR's Model 9500-60 **60 Gallon Receiver Tank** can be installed near the point of the high demand so there is an additional supply of compressed air available for a short duration at the point of use. It is intended for applications that require an intermittent demand for a high volume of compressed air. If sized properly, it can eliminate fluctuations in pressure and volume throughout the compressed air system and eliminating some points being "starved" for compressed air. The time between the high volume demand occurrences should be long enough so the compressor has enough time to replenish the EXAIR 60 Gallon Receiver Tank.

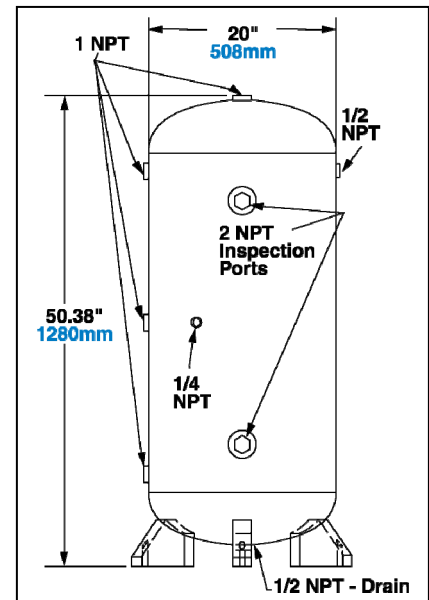

The 60 gallon vertical steel tank with mounting feet saves floor space and meets the American Society of Mechanical Engineers (ASME) pressure vessel code. (It is not ASME rated for vacuum.) A drain valve is provided for placement at the bottom of the tank to discharge liquid and contaminants. A user supplied check valve installed upstream of the receiver tank will maintain the tank at maximum pressure so upstream uses of compressed air do not deplete the tank. A user supplied needle valve can regulate the refilling of the receiver tank, effectively reducing the large intermittent air requirement into a smaller average demand.

The receiver tank must be installed so the drain and inspection ports are easily accessible. Under no circumstances can the receiver tank be buried underground or located in an inaccessible place. It is the user's responsibility to make sure the tank is in good working order by regularly depressurizing the tank and using the inspection ports to examine for deterioration and corrosion. Consult local codes for the frequency of these inspections. In many cases, a National Board of Boiler and Pressure Vessel Inspector will conduct the inspection.

A drain must be installed on the bottom of the receiver tank (at the lowest point) to provide removal of accumulated oil and water. It is important to open the drain valve to drain the tank regularly to prevent build up of liquid in the tank (once daily is recommended).

The receiver tank is supplied with a pressure gauge that should be located at a spot that is easily visible. The user supplied pressure relief valve installed on this Receiver Tank must be constructed, installed and maintained in accordance with the A.S.M.E. Boiler and Pressure Vessel Code, Section VIII Edition 1968.

This ASME Pressure Relief Valve must have a total relieving capacity to prevent pressure in the receiver from exceeding the maximum allowable working pressure of the receiver by more than 10 percent. When the exhaust of the pressure relief valve is connected to a discharge pipe, that pipe diameter must equal (or be greater) than the combined cross sectional area of the exhaust diameter of the valves discharging into it. The user provided discharge pipe should be directed to a safe place for the discharge to occur. The pressure relief valve should be tested regularly (at least monthly) to ensure it is in good operating condition. Check local codes that may apply.

If you have any questions or problems, please contact an EXAIR Application Engineer at:

Toll Free: 1-800-903-9247 (U.S. and Canada)
Telephone: (513) 671-3322 outside of U.S. and Canada
Toll Free Fax: 1-866-329-3924 (U.S. and Canada)
FAX: (513) 671-3363 outside of U.S. and Canada
E-mail: techhelp@exair.com
Website: www.exair.com